

A
B
C
D
E
F

A
B
C
D
E
F

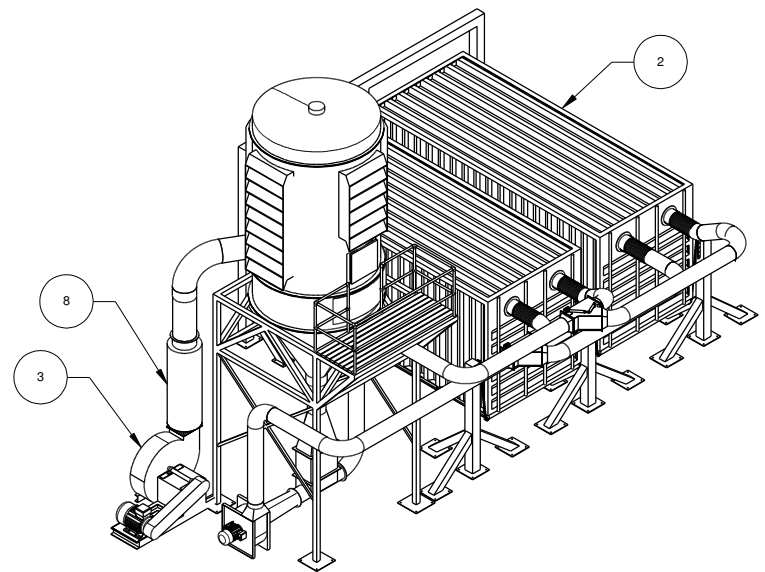
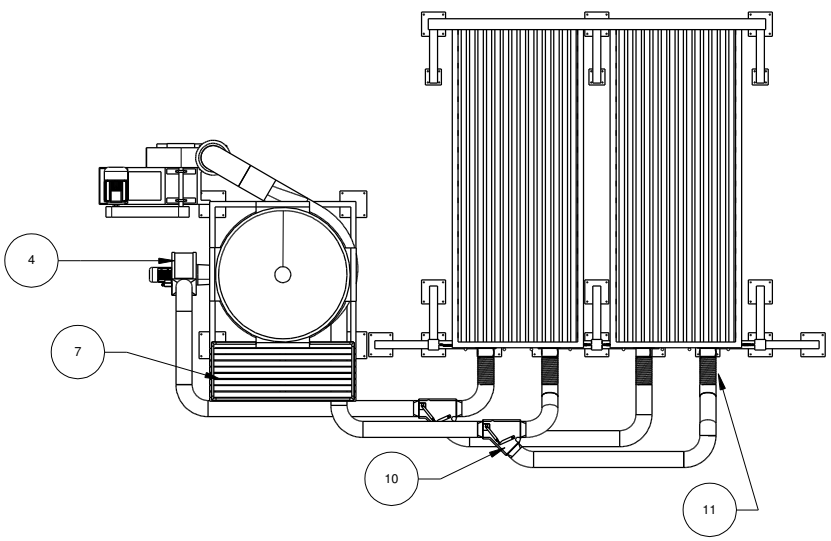
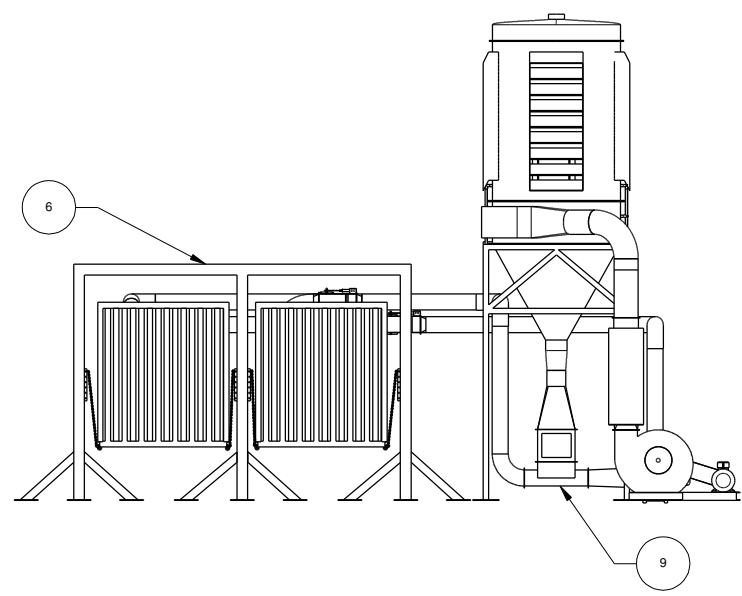
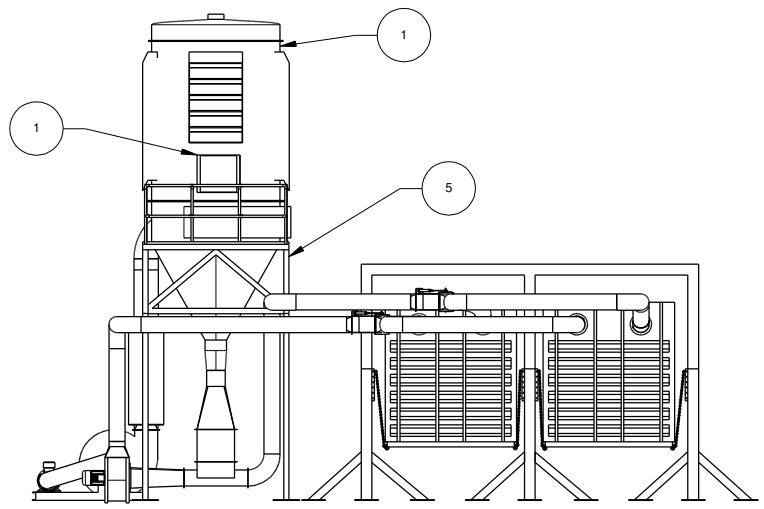

Item Number	Part Name
1	Filterclone
2	Collection Container
3	Main Fan
4	Bin Loading Fan
5	Filterclone Support Frame
6	Container Support Frame
7	Service Platform
8	Silencer
9	Bin Loading Feeder Chute
10	Diverter Valve
11	Flex Duct
12	Inspection Door

Itemref	Quantity	Title/Name, designation, material, dimension etc			Article No./Reference	
Drawn by	Checked by	Approved by - date	File name	Date	Scale	
Bin Loading System				Edition	Sheet	

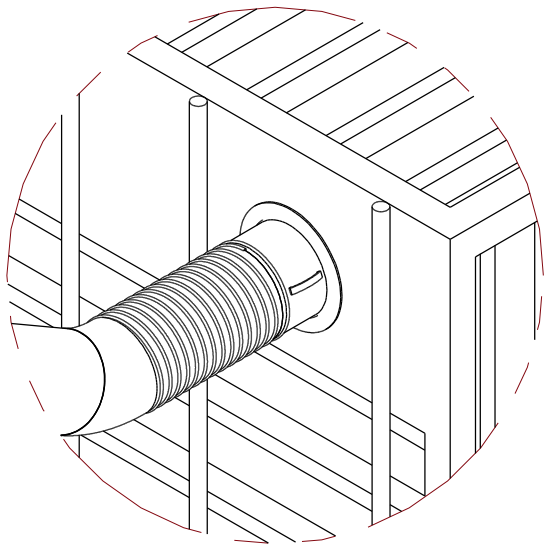

Flexible hose connection for quick and easy container change-over.

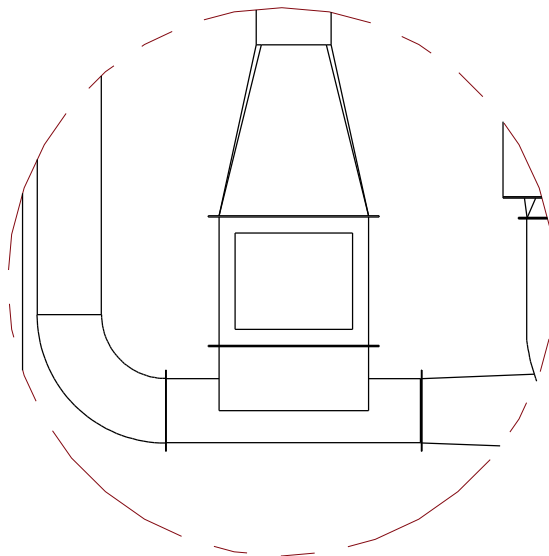

Drop chute window

Itemref	Quantity	Title/Name, designation, material, dimension etc			Article No./Reference	
Drawn by	Checked by	Approved by - date	File name	Date	Scale	
Bin Loading System					Edition	Sheet